

Wecryl WI Concrete Expansion Joint Waterproofing System, single layer

(abP-approved)

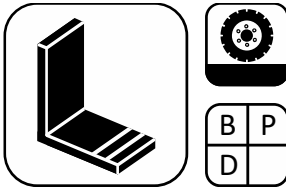

Brief description

The Wecryl Water-Impermeable (WI) Concrete Expansion Joint Waterproofing System is a high-quality, fleece-reinforced and permanently highly flexible system for the secure and reliable waterproofing of expansion joints in WI concrete. The elasticity range can be modified to accommodate even extremely large expansion joints.

The joint waterproofing system can be incorporated seamlessly in Wecryl waterproofing for the main area. Its liquid application and high bonding strength on almost any substrate make the system an optimum solution, especially for refurbishment projects.

Properties and advantages

- Highly flexible
- Flexible at low temperatures
- Adjustable elasticity (expansion) range
- Can be integrated seamlessly in Wecryl systems
- Permanently weather-resistant (resistant to high and low temperatures, UV rays, hydrolysis)
- Resistant to most commonly used acids and alkali solutions
- Easy and fast application
- Solvent-free

Applications

The Wecryl WI Concrete Expansion Joint Waterproofing system is used as permanently highly flexible waterproofing for WI concrete expansion joints as well as for waterproofing upstands on details. The system is used on balconies, in multi-storey car parks and on roofs.

Application conditions

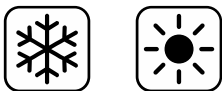

Temperatures

The system can generally be applied within an ambient temperature range between +3 °C and +35 °C. Some products are also suitable for application at sub-zero temperatures. Please refer to the table below for exact details.

Product	Temperature range, in °C		
	Air	Substrate*	Material
Primer layer			
Wecryl 176	+3 to +35	+3 to +50*	+3 to +30
Wecryl 178	+3 to +35	+3 to +50*	+3 to +30
Wecryl 176 K	+3 to +35	+3 to +50*	+3 to +30
Waterproofing layer			
Wecryl R 230	-5 to +35	+3 to +50*	+3 to +30
Wecryl R 230 thix	-5 to +35	+3 to +50*	+3 to +30
Wecryl R 230 TT	-15 to +25	-10 to +30*	+3 to +20

* The substrate temperature must be at least 3 °C above the dew point during application and curing.

Wecryl WI Concrete Expansion Joint Waterproofing System, single layer

(abP-approved)

Moisture

The relative humidity must be $\leq 90\%$.

The surface to be coated must be dry and ice-free.

The surface must be protected from moisture until the coating has hardened.

Consumption and reaction times

Product	Consumption [kg/m ²]		
	Substrate smooth	fine-sandy	coarse
Wecryl 176	approx. 0.4	approx. 0.5	approx. 0.8
Wecryl 178	approx. 0,4	approx. 0,5	approx. 0,8
Wecryl 176 K	approx. 0.8	approx. 0.9	approx. 1.0
Waterproofing layer			
Wecryl R 230 /-thix	approx. 3.5		
Wecryl R 230 TT	approx. 3.5		
WeFleece	1.00 rm/m		

Product	Reaction time (approx. values at 20 °C)			
	Pot life	Rainproof	Overlayable	Curing time
Wecryl 176	10 min	30 min	30 min	2 hours
Wecryl 178	10 min	30 min	30 min	2 hours
Wecryl 176 K	10 min	30 min	30 min	2 hours
Wecryl R 230 /-thix	15 min	30 min	1 hour	3 hours
Wecryl R 230 TT	20 min	45 min	75 min	6 hours

Application tools



Product	Application tool
Wecryl 176	Sheepskin roller
Wecryl 178	Sheepskin roller
Wecryl 176 K	Smoothing trowel
Wecryl R 230 /-thix /-TT	Sheepskin roller
WeFleece	Scissors, sheepskin roller

Substrate preparation and primer selection

Correct substrate preparation and a flawless primer coating are essential for ensuring the functional durability of the WestWood® System.

Generally the substrate must be sound, dry, and free from loose and adhesion-reducing particles. That is why coats of paint, cement slurry, dirt and grease, for instance, must always be removed completely. As a rule this is done by shot blasting, scarifying or grinding and then vacuuming off the debris.

The primer coating then applied creates an ideal barrier and enables optimum adhesion between the substrate and the WestWood® System. Please refer to the Application Guidelines - Substrate for the correct substrate preparation and primer selection.

Primer layer

The primer is applied to the prepared substrate.

The primer must be applied to a slightly larger area than the subsequent waterproofing system.



Installation guideline

Wecryl WI Concrete Expansion Joint Waterproofing System, single layer (abP-approved)

Wecryl 176 – Primer for absorbent substrates

Wecryl 178 – Primer for damp substrates

Use the sheepskin roller to apply an even film-forming coat of primer. Avoid creating puddles of primer.

Once the coating has cured, apply a second coat to cover any defects (bubbles, areas not fully coated).

Wecryl 176 K – Primer / Scratch-coat for highly absorbent mineral substrates

Apply an even and film-forming coat of primer with the smoothing trowel, using the particle size as a guide to the thickness of the layer. Any build-up of material should be avoided.

Once the coating has cured, apply a second coat to cover any defects (bubbles, areas not fully coated).

Levelling

Once the primer has hardened, smooth over areas of damage, height differences, broken or missing tiles or negative slope with Wecryl surfacer. Please refer to the Application Guidelines - Substrate.

Waterproofing of water- impermeable concrete expansion joints

Wecryl R 230 /-thix /-TT – Waterproofing

The primer and equalising layers must have hardened before the waterproofing can be applied.

Use PMMA Surfacer / Mortar to fill open joints so that they are flush with the adjacent areas. This can be done with a trowel or a brush.

Once hardened, apply joint tape along the joint. The joint tape must be at least five times wider than the maximum expected joint movement, but always at least 5 cm.

Then apply a generous and even layer of Wecryl R 230 mixed with catalyst to the entire area (at least 1.5 kg/m²), and immediately embed a strip of WeFleece strip along the centre of the joint and use a sheepskin roller to remove any air bubbles. The strip of fleece must be so wide that it extends at least a further 10 cm beyond either side of the joint tape. Directly afterwards, apply more material wet in wet, (at least 1.0 kg/m²) until the fleece is completely saturated.

Finally apply a covering layer of the same material (approx. 1.0 kg/m²) to the hardened resin.

In each case use a sheepskin roller to spread the material over the surface. Fleece overlaps must be installed with 5 cm overlap.

Wecryl WI Concrete Expansion Joint Waterproofing System, single layer

(abP-approved)



Example scheme: Fleece overlaps in corners:

It is vital that any subsequent layers (e.g. protective or wearing layers) are not applied to the area above the joint tape.

The area to be kept clear must be 1 -2- cm wider on each side than the joint tape.

Integration in systems for the main area (optional)

If not only the details and joints, but also the main areas are to be waterproofed using WestWood® systems, then they must be integrated with fleece-reinforced systems and with a fleece overlap of at least 5 cm.

In the case of expansion joints, no further system layers must be applied to the area above the joint tape (width of joint tape + 1 cm on either side).

Cleaning the tools

If work is interrupted or when it is completed, clean the tools thoroughly with WestWood® Cleaning Agent within the pot life of the material (approx. 10 minutes). This can be done with a brush. The tools are ready to be used again as soon as the cleaning agent has evaporated fully.

Simply immersing the tools in the Cleaning Agent will not prevent the material from hardening.

Information on safety and risks

Please refer to the safety data sheets for the products used.

General information

The above information, especially information about application of the products, is based on extensive development work as well as many years of experience and is provided to the best of our knowledge.

However, the wide variety of requirements and conditions on site mean that it is necessary for the product to be tested to ensure that it is suitable for the intended purpose. Only the most recent version of the document is valid. We reserve the right to make changes to reflect advances in technology or improvements to our products.

Appendix

System drawings

Rev.: 01 November 2022

System drawing

Wecryl WI Concrete Expansion Joint Waterproofing System, single layer (abP-approved)

WI concrete expansion joint, surface

Substrate

- 1 WI concrete, mechanically pre-treated
- 2 Insulation
(if not installed,
embed closed-cell round cord)

Primer

- 3 Wecryl 176 or Wecryl 178

Levelling

- 4 PMMA Surfacer / Mortar

Waterproofing layer

- 5 Joint tape

Waterproofing layer

- 6 Wecryl R 230
- 7 WeFleece
- 8 Wecryl R 230
- 9 Wecryl R 230

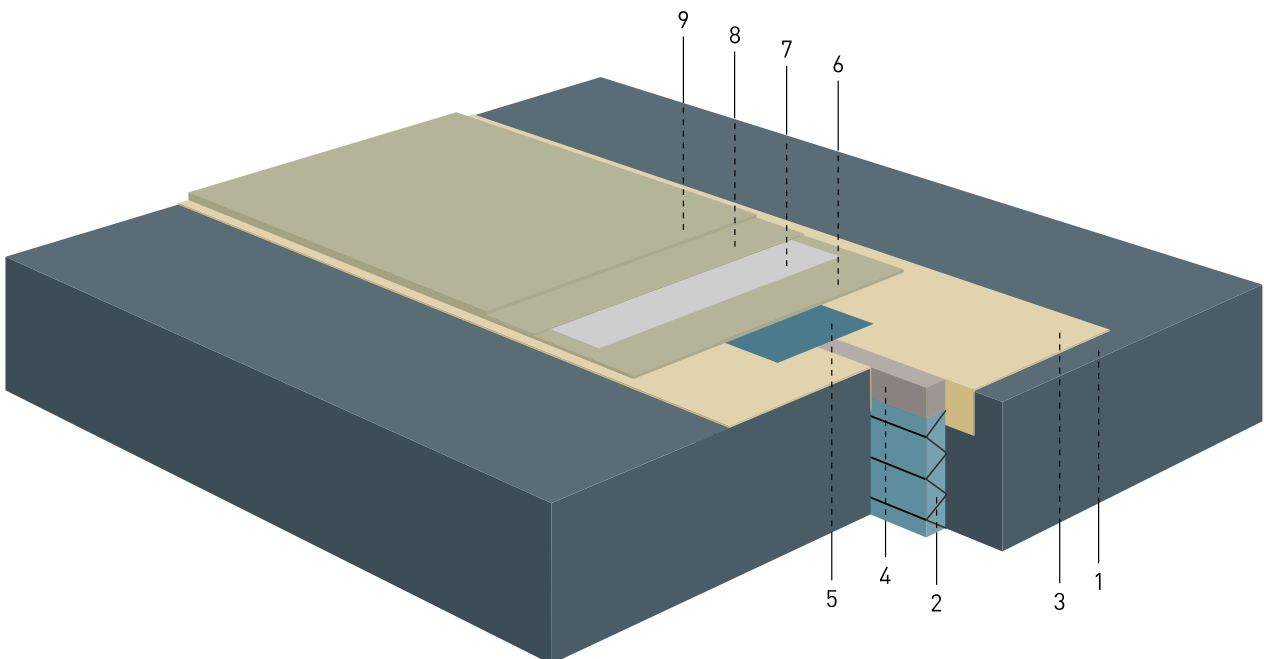

System drawing

Wecryl WI Concrete Expansion Joint Waterproofing System, single layer (abP-approved)

WI concrete expansion joint, upstand

Substrate

- 1 WI concrete, mechanically pre-treated
- 2 Insulation
(if not installed,
embed closed-cell round cord)

Primer

- 3 Wecryl 176 or Wecryl 178

Levelling

- 4 PMMA Surfacer / Mortar

Waterproofing layer

- 5 Joint tape

Waterproofing layer

- 6 Wecryl R 230
- 7 WeFleece
- 8 Wecryl R 230
- 9 Wecryl R 230

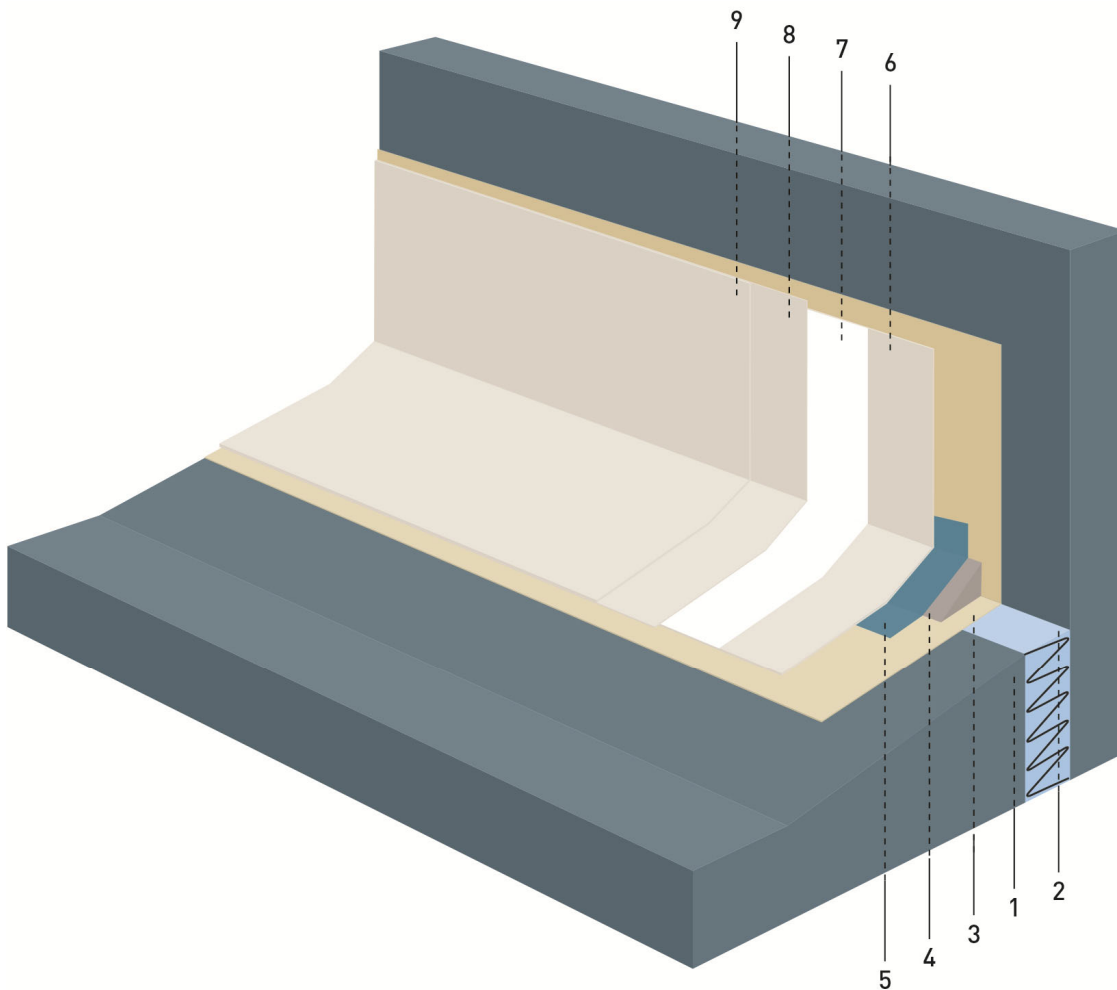

Rev.: 01 November 2022

westwood_gb-en_vr_wecryl_WI_concrete_expansion_joint_waterproofing_system_abp